

PLAN VIEW—WATER
NTS

PLAN VIEW—SEWER
NTS

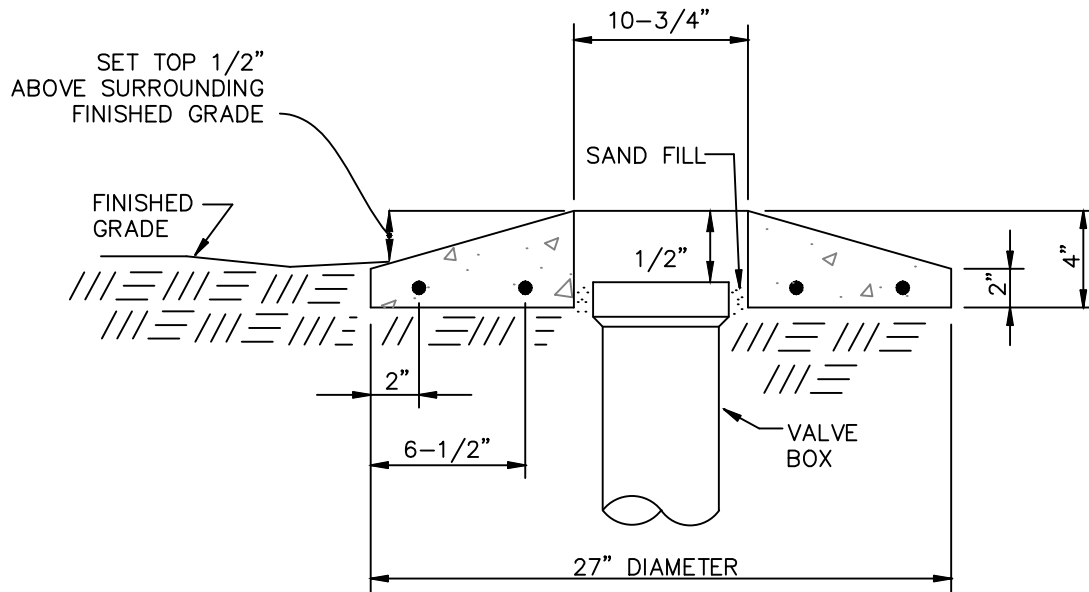

SECTION A—A
NTS

NOTE:

1. VALVE BOX PROTECTOR RINGS SHALL BE INSTALLED AROUND VALVE BOX IN UNPAVED NON-TRFFIC AREAS AND SHALL NOT CREATE A HINDRANCE TO FUTURE MOWING OPERATIONS.
2. CONCRETE PROTECTOR RING SHALL BE CONSTRUCTED OF 2500 PSI PRECAST REINFORCED CONCRETE.
3. VALVE BOX SHOULD BE PLACED AT GRADE WITH VALVE BOX PROTECTOR RING EXTENDING $\frac{1}{2}$ " ABOVE GRADE.
4. FILL VOID BETWEEN GRADE RING AND VALVE BOX TOP SECTION WITH NON-SHRINK GROUT.

CITY OF ROCK HILL
UTILITIES DEPARTMENT
757 S. ANDERSON ROAD
ROCK HILL, SC 29730



STANDARD DETAIL

VALVE PROTECTOR RING

REVISIONS:	DATE:	FILE NAME
	FEB. 2018	12.04
	SCALE:	
	N.T.S.	